



Telephone Paging Amplifier 250-Watt Model

Installation and Use Manual

Issue 4, February 2010

© 1999 Bogen Communications, Inc.
All rights reserved. 54-2023-01D 1002

LU250WAMP: MAT# 408186096

Select Code: 701-000-116

NOTICE: Every effort was made to ensure that the information in this guide was complete and accurate at the time of printing. However, information is subject to change.

WARNING: To reduce the risk of Fire or Electric Shock, Do Not Expose this apparatus to rain or moisture.

Apparatus shall not be exposed to dripping or splashing and no objects filled with liquids, such as vases shall be placed on the apparatus.

WARNING: Only connect unit to AC mains outlet providing protective earthing connection.

NOTE: Mains plug is used as disconnect device from the mains and shall remain readily accessible and operable.

CAUTION: These servicing instructions are for use by qualified service personnel only. To reduce the risk of electric shock, do not perform any servicing other than that contained in the operating instructions unless you are qualified to do so.

Always follow these basic safety precautions when installing and using the unit:

IMPORTANT SAFETY INSTRUCTIONS

1. Read these instructions.
2. Keep these instructions.
3. Heed all warnings.
4. Follow all instructions.
5. Do not use this apparatus near water.
6. Clean unit with dry cloth.
7. Do not block any ventilation openings. Install in accordance with the manufacturer's instructions.
8. Do not install near any heat sources such as radiators, heat registers, stoves, or other apparatus (including amplifiers) that produce heat.
9. Do not defeat the safety purpose of the polarized or grounding-type plug. A polarized plug has two blades with one wider than the other. A grounding-type plug has two blades and a third grounding prong. The wide blade, or the third prong, are provided for your safety. If the provided plug does not fit into your outlet, consult an electrician for replacement of the obsolete outlet.
10. Protect the power cord from being walked on or pinched particularly at plugs, convenience receptacles, and the point where they exit from the apparatus.
11. Only use attachments/accessories specified by the manufacturer.
12. Unplug this apparatus during lightning storms or when not used for long periods of time.
13. Refer all servicing to qualified service personnel. Servicing is required when the apparatus has been damaged in any way, such as power-supply cord or plug is damaged, liquid has been spilled or objects have fallen into the apparatus, the apparatus has been exposed to rain or moisture, does not operate normally, or has been dropped.

CAUTION

**RISK OF ELECTRIC SHOCK
DO NOT OPEN**



CAUTION: TO PREVENT THE RISK OF ELECTRIC SHOCK, DO NOT REMOVE ANY FRONT/BACK COVERS OR PANELS. NO USER-SERVICEABLE PARTS INSIDE. REFER SERVICING TO QUALIFIED PERSONNEL.

The lightning flash with arrowhead symbol, within an equilateral triangle, is intended to alert the user to the presence of uninsulated "dangerous voltage" within the product's enclosure that may be of sufficient magnitude to constitute a risk of electric shock to persons.

The exclamation point within an equilateral triangle is intended to alert the user to the presence of important operating and maintenance (servicing) instructions.

Contents

	Page
INTRODUCTION	3
PACKAGE CONTENTS	3
INSTALLATION	4
Mounting	4
<i>Wall Mounting.....</i>	<i>4</i>
<i>Rack Mounting</i>	<i>4</i>
WIRING CONNECTIONS	5-9
Input Wiring	5
<i>TEL Input and Control Pair</i>	<i>5</i>
<i>TEL Input to Universal Coupler.....</i>	<i>6</i>
<i>Music Input</i>	<i>6</i>
<i>Microphone Input.....</i>	<i>6</i>
<i>Night Ringer Connections.....</i>	<i>7</i>
<i>Bridging Inputs.....</i>	<i>7</i>
<i>Input Cover Replacement.....</i>	<i>7</i>
Output Wiring.....	8
<i>Speaker Connection</i>	<i>8</i>
Line-Matching Transformer	9
<i>LUWMTIA Connector</i>	<i>9</i>
<i>Output Cover Replacement.....</i>	<i>9</i>
OPERATION	10-11
Indicators.....	10
Controls	10-11

Telephone Paging Amplifier

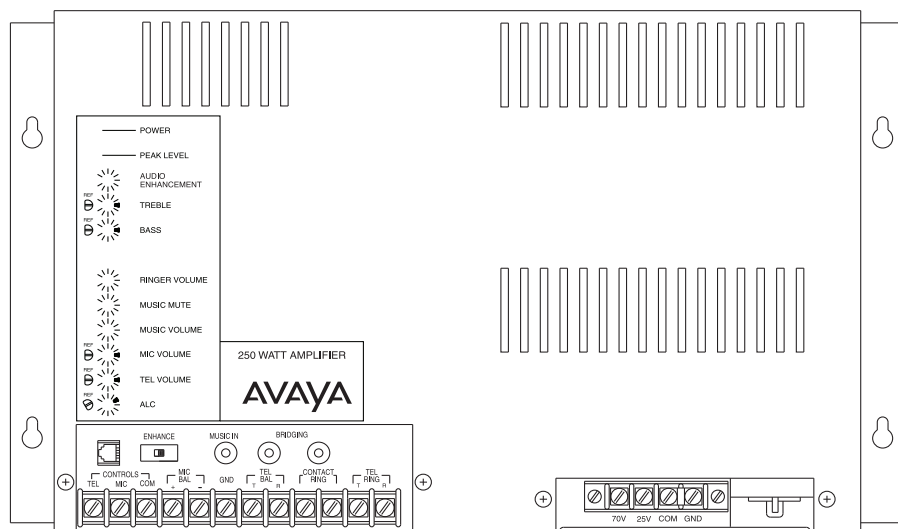

Figure 1: Telephone Paging Amplifier

Introduction

This document describes the Avaya 250-watt Telephone Paging Amplifier. These are full-featured, wall-mounted amplifiers that provide inputs for dry loop 600-ohm telephone page signal, background music source, and low impedance microphone. A set of control inputs allow an external contact closure to mute background music and open the telephone page channel. Background music mute level during a page is adjustable and the music slowly fades back in after the page is completed. An automatic level control system limits the output level of the telephone page channel so that differences in the volume of the paging party's voice will be less noticeable. Bass and treble controls are provided for adjusting the quality of the output signal. An Audio Enhancement feature is also provided. Audio Enhancement improves the clarity of the output signal by replacing the higher frequency harmonics that are normally lost through the telephone system. This amplifier includes a built-in night ringer that can be triggered by either a standard telephone (analog) ring signal or an external contact closure. The night ringer mutes the background music, but not pages.

Package Contents

- Telephone Paging Amplifier unit
- 4 wall-mounting screws
- Installation and Use Manual

Before You Start Review the contents of the box. Read through this entire manual to understand how this product installs and operates.

NOTE: Be sure you have enough 22 AWG shielded, twisted pair wire (MAT# 401882956) for your speaker runs.

Figure 2: Wall Mounting the Amplifier

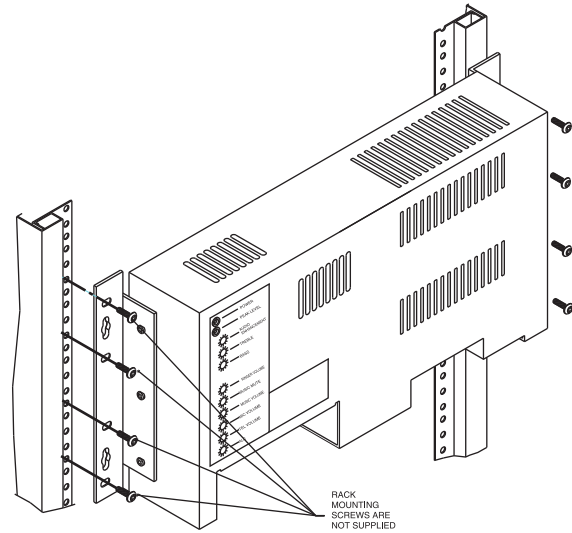
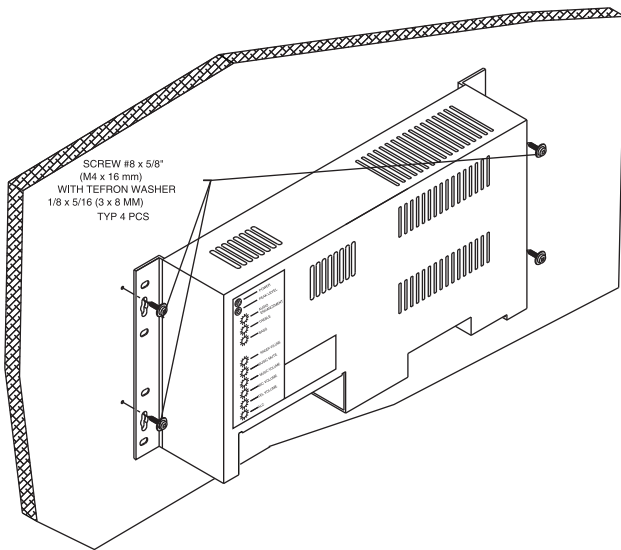

Figure 3: Rack Mounting the Amplifier

Installation

Mounting

The amplifier is designed for wall mount applications but can also be mounted in a standard 19" rack. The 250W amplifier weighs 31 lb.

NOTE: The amplifier will produce heat during operation which will rise and may cause problems for temperature-sensitive equipment mounted above it. Mount the amplifier near the top of the backboard (for wall mounting) or rack (for rack mounting) so that no other equipment will be above it. If this is not possible, then allow at least 12" between the top of the amplifier and the bottom of any equipment positioned above it. Also allow at least 6" between the bottom of the amplifier and any equipment below it to allow for adequate air circulation.

Wall Mounting

To wall mount this unit, use the four 5/8" pan head screws with nylon washers provided (see Figure 2). Insert the top two screws first leaving the heads protruding about 1/4". Lift the amplifier and place it over the 2 screws using the top keyhole slots in the flanges at the sides of the amplifier. Allow the amplifier to rest on the 2 screws and then proceed to insert the bottom 2 screws into the lower keyhole slots. With all the screws in place, tighten the screws to secure the amplifier.

NOTE: Backboard must be a minimum of 3/8" thick plywood and securely mounted to the wall.

Rack Mounting

The amplifier was designed to mount directly to standard 19" racks using the mounting flanges as shown in Figure 3 (rack screws are not supplied). In the factory set position, the unit will protrude from the front of the rack. This provides the best ventilation of the unit and easier access to the wiring connections.

NOTE: The unit can also be mounted partially recessed in the rack by reversing the mounting flanges. Unscrew the mounting flanges (3 screws mount the flange to the cover) and install them in a flipped over orientation. This position will provide adequate ventilation and centers the weight of the unit over the rack rails.

Wiring Connections

Important: Before making any connections or wiring changes to the amplifier or any equipment connected to the amplifier, make sure that the amplifier is NOT plugged into an AC outlet.

NOTE: The amplifier does not have a power switch, so it must be unplugged in order to turn the power off.

Input Wiring

All signal input and control wiring is made to the terminal strip and RCA connectors beneath the left side access cover. Loosen the two Phillips-head screws on each side of the cover and remove it.

TEL Input and Control Pair

The telephone input is a 600-ohm, dry loop, balanced input available at the T and R terminals. It is controlled by a dry contact closure that is made between the control terminals labeled TEL and COM. Shorting these terminals together will mute the background music input and open the Tel page channel (see Figure 4).

NOTE: In instances where the amplifier is to be placed permanently in the Tel page mode, a wire jumper must be installed between the TEL and COM terminals.

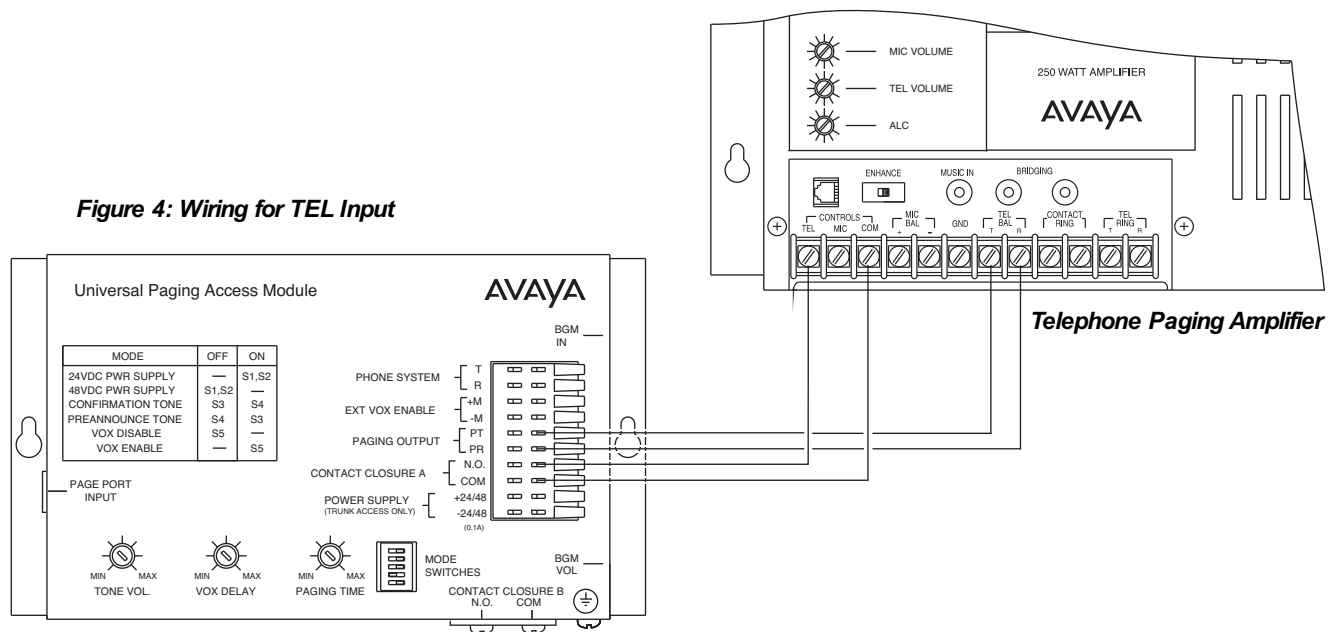

Tel Input to Universal Coupler After properly connecting your Universal Coupler (909) to your auxiliary trunk port, set your switches as follows: C1/C2 to C2; Rocker Switch 3 closed; and all others open. Coming out of the J2 Jack of the Coupler, connect the blue/white pair to the amplifier Tip and Ring. Connect the brown/white pair to Tel and Com on the control terminals.

Music Input A single RCA connector is provided for the connection of a background music source. Use a male RCA-to-RCA cable (not included) to make this connection. This is a mono input and requires that the output of stereo sources be converted to mono by using a Y-adapter (not included). Use a LUWMT1A to balance the music input, if necessary, to reduce hum/noise from a grounded music source.

Microphone Input A high gain, low impedance microphone input is provided in this amplifier. It is designed to work with balanced microphones. Connect the microphone's black wire to the amplifier's "-" (negative) terminal under the MIC BAL connections. Connect the microphone's Red wire to the "+" (positive) terminal. Connect the shield wire from the microphone to the adjacent GND terminal. Connect the microphone's white lead to the Control terminal marked MIC and the green lead to the COM. (See Figure 6.)

Two conductor shielded microphone wire should be used to extend the cable from the microphone. 22 AWG shielded, twisted pair speaker cable (MAT# 401882956) will also work. When extending microphone cable, be sure to connect the shields of the microphone cable to the extension wire.

Figure 6: Connect Microphone to Telephone Paging Amplifier

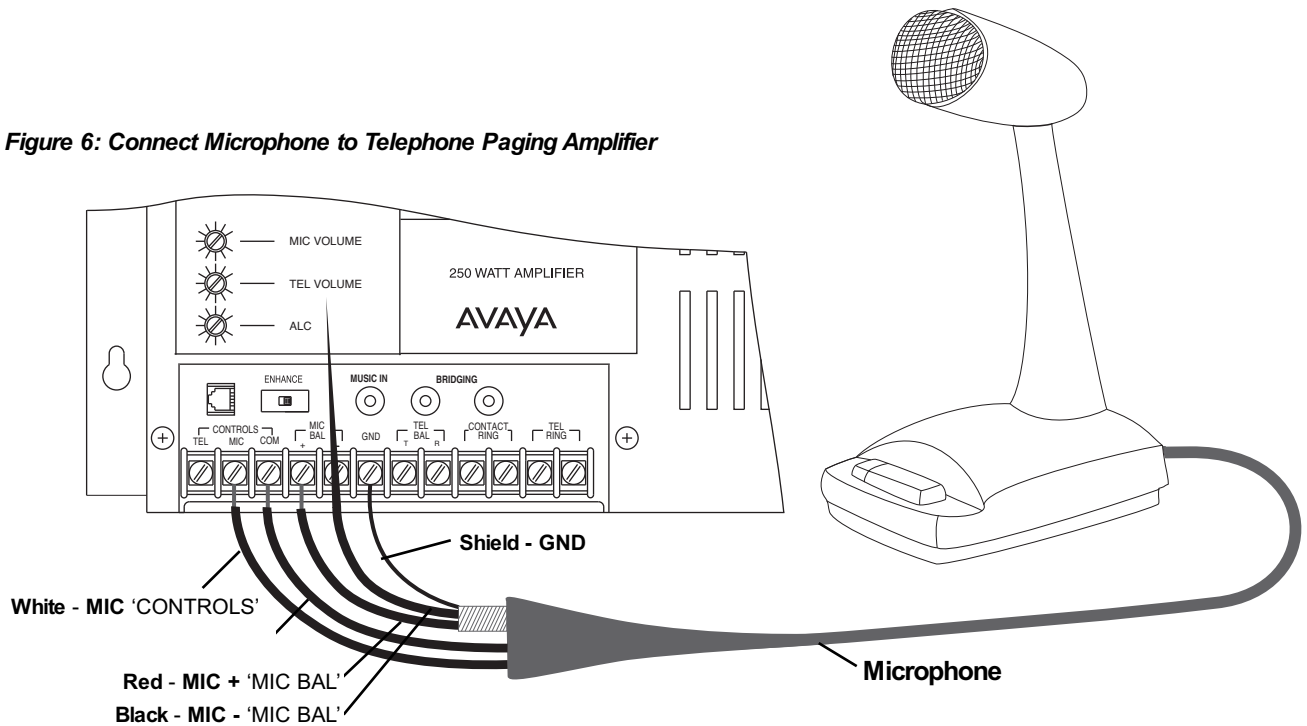

Night Ringer Connection

Either a standard telephone (analog) ring signal (90 - 105 V AC, 20 - 30 Hz) or an external contact closure activates the night ringer function of the amplifier. To activate the night ringer using standard telephone (analog) ring, connect the analog station's tip lead to the TEL RING "T" terminal and connect the ring lead to the "R" terminal. If using an external contact closure, connect the closure pair across the CONTACT RING terminals (not polarized). The night ringer follows the cadence of the activating signal.

Bridging Inputs

Bridging allows two amplifiers to be used in tandem to increase the total output power of the system. For example, when two 250-watt amplifiers are bridged, the total output capacity is 500 watts. Bridging is also a means by which to increase the number of amplifier inputs to an amplifier by using the input stage of a second amplifier (see Figure 7). The inputs of two or more amplifiers can be combined by using the bridging connections provided on these amplifiers. An RCA-to-RCA cable (not included) is used to connect the bridging jacks of different amplifiers together. Once bridged, each amplifier will amplify the inputs present on both amplifiers. The level control of a particular input on an amplifier will control the volume of this signal on both amplifiers. The cable used to bridge amplifiers should not exceed 20 feet in length.

NOTE: You can only bridge up to 3 amplifiers at one time. 250-watt amplifiers can only be bridged with other 250-watt amplifiers.

Input Cover Replacement

When all connections are made, remove an appropriate knockout on the input cover. Replace the cover and tighten the screws while dressing the wires through the knockout hole.

Figure 7: Bridging Inputs

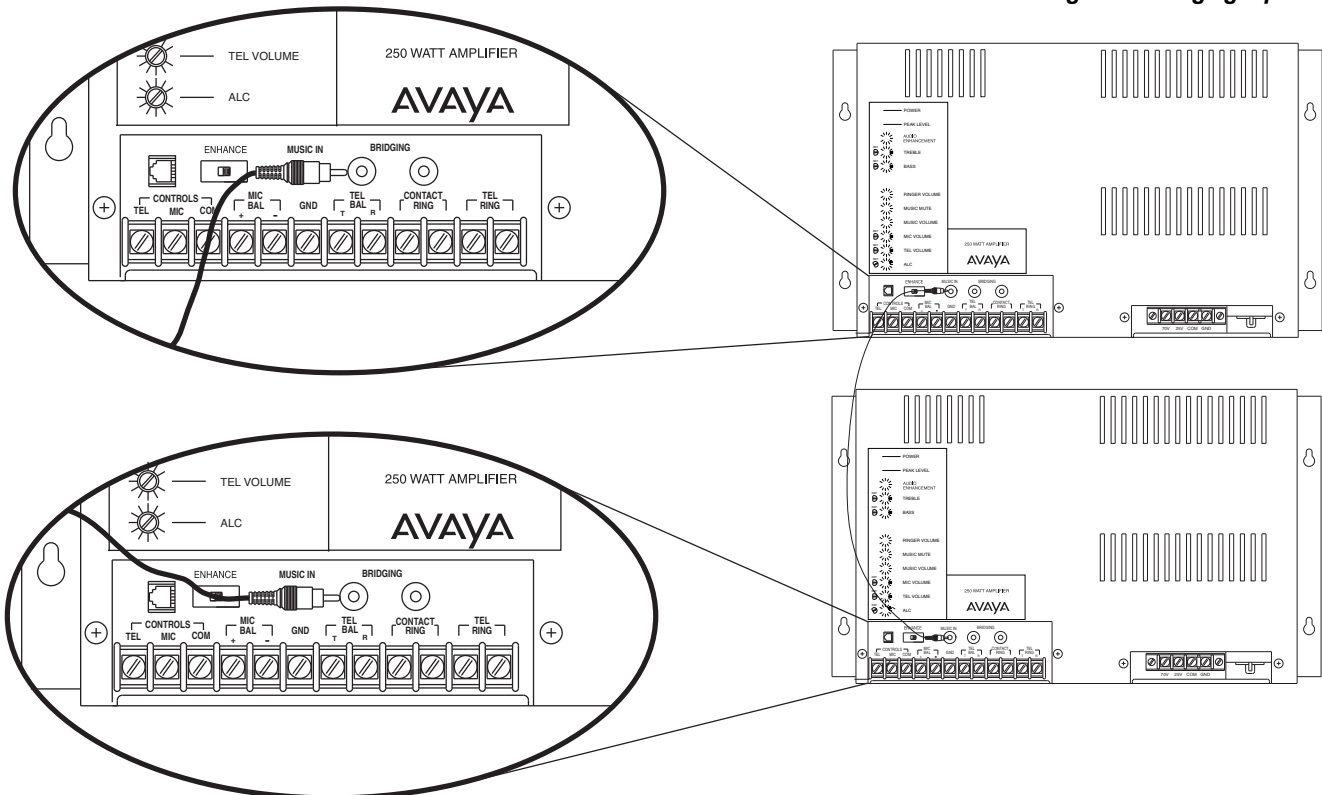

Output Wiring

All output wiring connections are made to the terminal strip located under the right side access panel. Loosen the two Phillips-head screws on each side of the cover and remove the cover.

Important: Before making any connections or wiring changes to the amplifier or any equipment connected to the amplifier, make sure that the amplifier is NOT plugged into an AC outlet.

NOTE: The amplifier does not have a power switch, so it must be unplugged in order to turn the power off.

Speaker Connection

70-volt speaker connections are made between the 70V and COM terminals on the output terminal strip (see Figure 8). Use a 22 AWG shielded, twisted pair cable (MAT# 401882956). Connect the shield of the cable to the GND terminal of the output terminal strip. The COM and GND terminals of the output terminal strip are connected using a shorting clip. The shorting clip enables the amplifier output to act as an unbalanced output (one side of the output connected to ground). If desired, the output can be made to be a balanced output with no connection to ground. To balance the output, simply remove the shorting clip. All speaker connections remain the same as above including connecting the shield to the GND terminal.

NOTE: The amplifier output terminal strip also includes terminals for 25V and 70V speaker connections. These are provided for special applications and are generally not used.

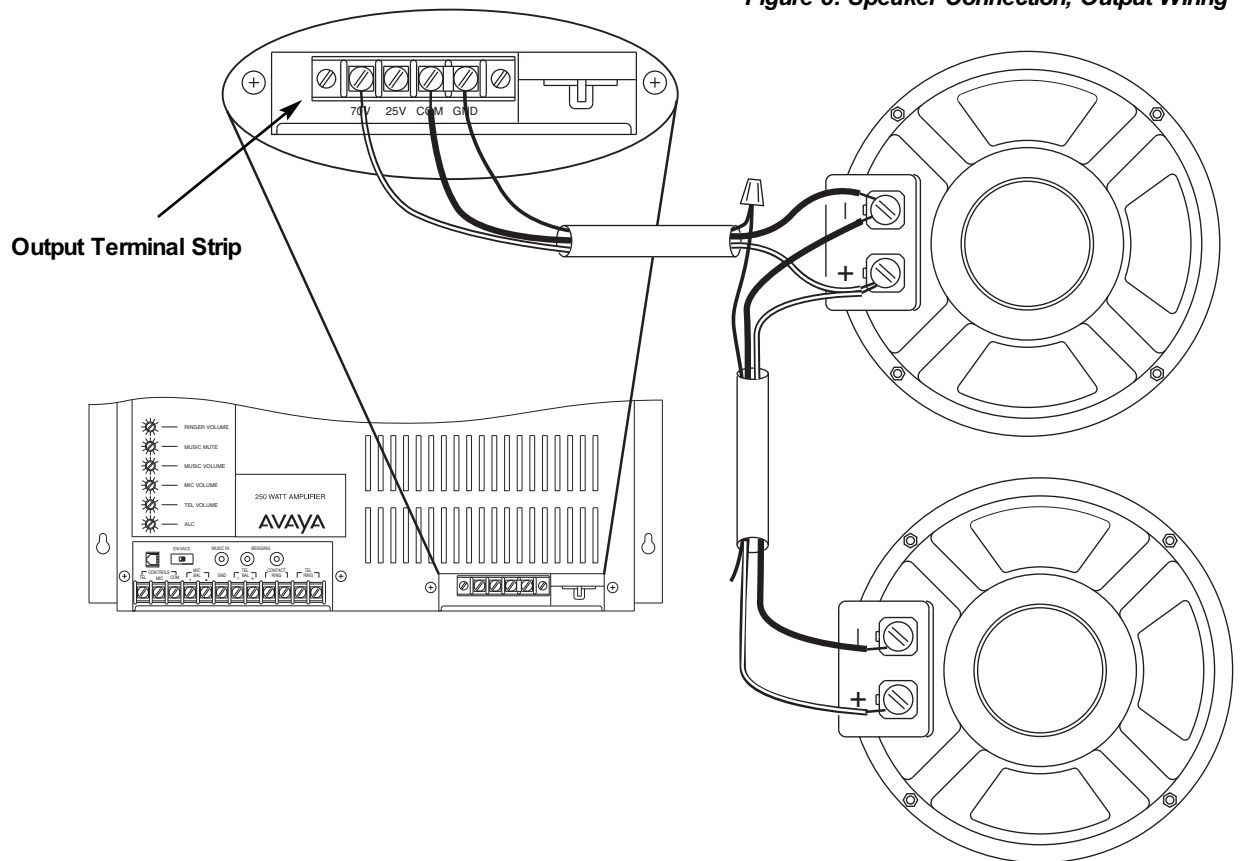

Figure 8: Speaker Connection, Output Wiring

Line-Matching Transformer

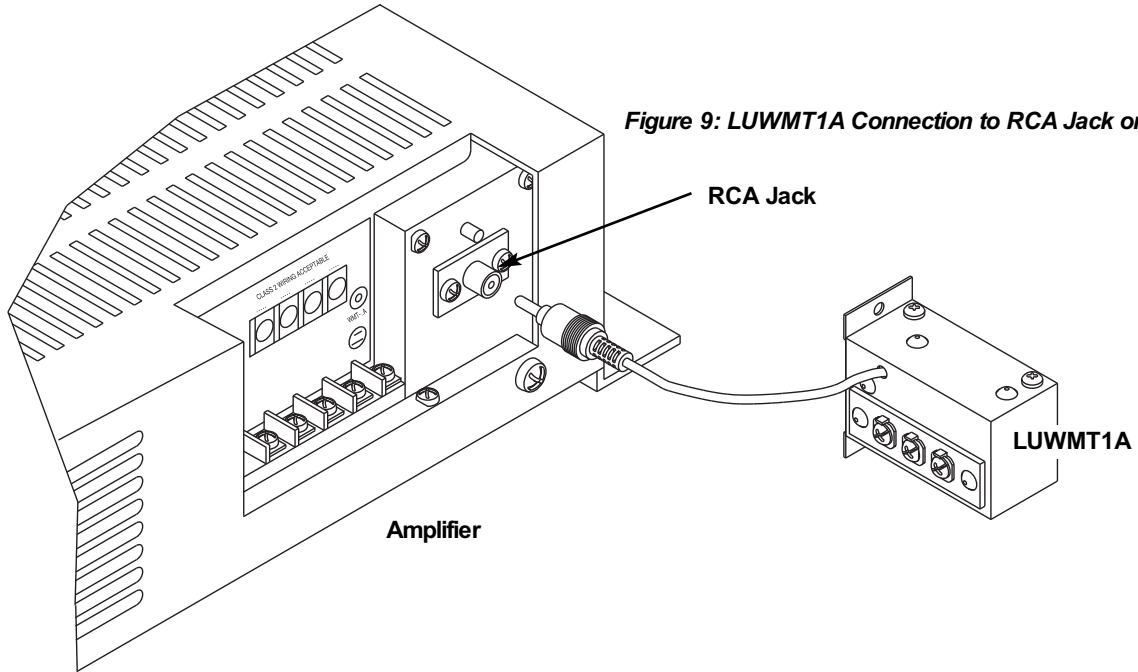

Figure 9: LUWMT1A Connection to RCA Jack on Amplifier

LUWMT1A Connector

An RCA jack is provided near the output terminal strip for connection to an LUWMT1A impedance matching transformer (MAT# 405891680). A 600-ohm, balanced telephone level output signal can be obtained by plugging the RCA connector of the LUWMT1A into this jack and taking the output signal off of the LUWMT1A screw terminals (see Figure 9). This is useful for driving long line when connecting to remote equipment.

NOTE: For information on connecting Telephone Paging Amplifiers to the AVAYA PCM Paging System Zone Controller (model LUPCMALL), please refer to the LUPCMALL instruction manual.

Output Cover Replacement

When all output connections are made, remove the appropriate knockout on the input cover. Replace the cover and tighten the screws while dressing the wires through the knockout hole.

Operation

Important: Before plugging the amplifier into an AC outlet, turn all volume controls to their full counterclockwise positions and all other controls to their reference position or to mid rotation.

Indicators

POWER IND The POWER IND LED illuminates whenever AC power is applied to the amplifier (there is no power switch on the amplifier).

PEAK LEVEL The PEAK LEVEL LED illuminates whenever the speaker output signal level approaches its maximum level. This indicator is used when setting volume levels. Maximum output level is achieved when the PEAK LEVEL indicator flashes intermittently on loud peaks of the input signal. If the indicator illuminates steadily, the output signal volume is set too high and distortion is occurring. Decrease the volume control for the appropriate input until the indicator flashes only occasionally.

Controls

TEL VOLUME This control adjusts the level of the telephone page output. A reference level setting position is provided with this control. When set to this position, the output level of the page should be about maximum. Further adjustment can be made using the PEAK LEVEL indicator described above.

ALC The ALC controls the level at which the amplifier will begin to limit the output signal level. A reference setting position is provided for this control. Normally, the reference position provides optimum performance; however, if further adjustment is desired, use the following steps for setting the ALC control.

Manual Output Adjustment Procedure (follow only if minor adjustments to the reference settings are not adequate)

- 1) Disable ALC by turning the ALC control to the maximum counterclockwise position.
- 2) Make a page, speaking softly, yet distinctly. Set the TEL VOLUME control to the desired paging level during this page.
- 3) Make another page, speaking relatively loudly this time. Rotate the ALC control clockwise while making the page, until it has the same loudness as the first page.

NOTE: The TEL Volume and ALC controls work together to set the output level. When both controls are set to the reference positions, the amplifier provides a nominal 70V signal output (optimum).

NOTE: The PEAK LEVEL indicator should not show excessive peaking during loud pages. If this is occurring, the ALC control must be further increased.

MUSIC VOLUME This control adjusts the level of the background music output. No reference level setting position is provided. The background music level should be set to an acceptable level without overdriving the system. When adjusting this level, the PEAK LEVEL indicator should be observed to ensure that the amplifier signal is not distorted.

MUSIC MUTE This control adjusts the level of the background music heard during a paging announcement. No reference level setting position is provided. The background music mute level should be set to the customer's satisfaction, but the page announcement must always be easily heard above the background music.

MIC VOLUME This control adjusts the level of the microphone page output. A reference level setting position is provided with this control. When set to this position, the output level of the page should be about maximum. Further adjustment can be made by observing the PEAK LEVEL indicator.

CAUTION: Microphone should not be placed near any paging loudspeakers.

RINGER VOLUME This control adjusts the level of the night ringer tone output. No reference level setting position is provided. The background music level should be set to the customer's satisfaction. When adjusting this level, the PEAK LEVEL indicator should be used to ensure that the amplifier signal is not distorted.

AUDIO ENHANCEMENT This control adjusts the amount of Audio Enhancement effect circuitry that is mixed in to the page signal. No reference position is provided for this feature. To use this function, the Audio Enhancement switch beneath the input connection cover must be set to ON. Setting this switch to OFF bypasses the Audio Enhancement effect and makes the control inoperable. With the Audio Enhancement switch turned on, make a page and rotate the control until the audio sounds crisp and clear.

BASS and TREBLE Bass and treble controls are provided to adjust the high frequency and low frequency response of the paging system. Reference positions are provided for these controls. When set to these positions, the frequency response of the system will be flat. Set the controls to the customer's satisfaction. Clockwise rotation increases (boosts) the response and counterclockwise reduces (cuts) the response. Increasing bass and/or treble can cause output signal peaks to increase. Check the PEAK LEVEL indicator after making bass adjustment and lower the music input volume if excess peaking occurs.

Notes

AVAYA
